

MEDICAL FLOOR SCALES

PRODUCT NUMBER 7716, 7717, 7718

Medical, health and well-being

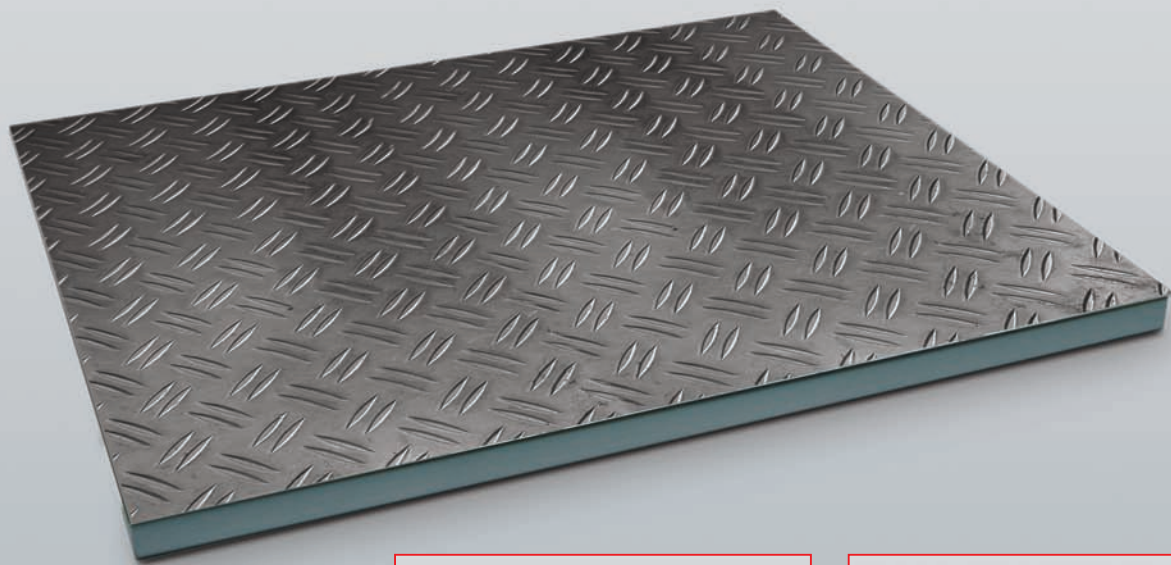

- › Floor scales for setting on-site or floor-even installation
- › Robust, flat construction
- › Painted steel or stainless steel
- › 4 platform sizes
- › Weighing range up to 1500kg
- › Approvable and with MPG-Certificate

Characteristics

Floor scales can be used universally and weigh human beings while standing, seating, sitting in a wheel chair, lying on a stretcher or in beds. The scales can be installed freely and accessed via drive-on ramps or installed floor-even. The space-saving floor-even installation allows for easy passing or driving through if no weighing operation takes place.

Version

- › Fully electronic floor scale in robust, generously sized steel tube construction
- › High overload security and maintenance-free construction
- › Direct load transmission on four DMS load cells
- › Extra flat construction from 80mm installation height
- › Appropriate for floor-even installation or for free setting on the ground
- › Measuring cable length 6m, optional also for plug connection
- › Standard as two-range scale with 2 x 3000e, approvable according to Class III, medicine product according to 93/42/EWG (MPG)

Indicator/Operating Device

The floor scales can be operated with two different indicators. The indicator 2790 for simple weighing functions or the indicator 3020 with additional functions.

The floor scale for weighing of human beings in hospitals, rehabilitation centres, caring institutes, clinical nutrition, dialysis. Also a solution for you? We are looking forward to assist you in your decision. Request a quotation by indicating the required weighing bridge and indicator. On demand, we are helpful in placing a service partner for appropriate mounting close to your location.

Indicator 2790



Simple indicator with tare function in addition to BMI-, Hold- or dialysis function (temporary tare), keypad with 5 keys for On/Off, Zeroing, Taring, Printing, backlighted LCD-display with 20mm high figures, wall or table mounting possible, including bracket, power supply 230 Volt.

Order Number	Description
2790.05.001	Digital-Indicator
2790.05.002	Digital-Indicator with interface RS 232 for printer EDV

Indicator 3020



Indicator with additional functions, tare functions with opportunity for hand tare input, tare memory, orga-data acknowledgement (patient, carer, account number, etc.), in addition to BMI-, Hold- or dialysis function (temporary tare), keypad with 19 keys, backlighted point-matrix-display, key lock for locking single non-relevant function keys, interface for printer or data processing as standard, table and wall version available, power supply 230 Volt.

Order Number	Description
3020.05.001	Table version
3020.05.002	Wall-/Stand bracket (+Wall bracket)

Floor scale 7716, painted, bolted



Made of painted steel, bolted weighing platform. Load cells made of anodized aluminium, Protection Class IP 65, corrosion resistant plastic terminal box, painting light-grey, weighing platform black.

Order Number	Weighing Range	Divisions	Load Capacity	Platform Size
Platform	kg	1st range g/ 2nd range g	kg	mm
smooth				
7716.02.001	600	100/200	1500	800 x 1000 x 80
7716.12.001	600	100/200	3500	1000 x 1250 x 80
7716.13.001	1500	200/500	3500	1000 x 1250 x 80
7716.22.001	600	100/200	3500	1250 x 1500 x 80
7716.23.001	1500	200/500	3500	1250 x 1500 x 80
7716.33.001	1500	200/500	3500	1500 x 2000 x 100

Floor scale 7717, stainless steel, bolted



Made of stainless steel 1.4301, bolted weighing bridge. Load cells made of stainless steel, Protection Class IP 68, corrosion resistant plastic terminal box, clean-friendly construction.

Order Number	Order Number	Weighing Range	Divisions	Load Capacity	Platform Size
Platform	Platform	kg	1st range g/ 2nd range g	kg	mm
smooth	structured				
7717.02.001	7717.02.002	600	100/200	1500	800 x 1000 x 80
7717.12.001	7717.12.002	600	100/200	3500	1000 x 1250 x 80
7717.13.001	7717.13.002	1500	200/500	3500	1000 x 1250 x 80
7717.22.001	7717.22.002	600	100/200	3500	1250 x 1500 x 80
7717.23.001	7717.23.002	1500	200/500	3500	1250 x 1500 x 80
7717.33.001	7717.33.002	1500	200/500	3500	1500 x 2000 x 100

Floor scale 7718, stainless steel, hinged



Made of stainless steel 1.4301, hinged weighing bridge with gas-filled strut (pressure tube painted in black) for easy access to scale pit. Load cells made of stainless steel, Protection Class IP 68, corrosion-resistant plastic terminal box, easy-to-clean construction.

Order Number	Order Number	Weighing Range	Divisions	Load Capacity	Platform Size
Platform	Platform	kg	1st range g/ 2nd range g	kg	mm
smooth	structured				
7718.02.001	7718.02.002	600	100/200	1500	800 x 1000 x 80
7718.12.001	7718.12.002	600	100/200	3500	1000 x 1250 x 80
7718.13.001	7718.13.002	1500	200/500	3500	1000 x 1250 x 80
7718.22.001	7718.22.002	600	100/200	3500	1250 x 1500 x 80
7718.23.001	7718.23.002	1500	200/500	3500	1250 x 1500 x 80

Accessories for Floor Scales 7716, 7717, 7718

Installation frame for floor-even installation

Made of stainless steel 1.4301
Please request a foundation plan!

Order Number	Platform Size	Load Capacity
	mm	kg
2501.05.001	1000 x 800	1500
2501.05.002	1250 x 1000	3500
2501.05.003	1500 x 1250	3500
2501.05.005	2000 x 1500	3500

Installation kit for on-floor set scales

Mounting kit consisting of 2 base plates, bolts, dowels and washers.

Order Number	Platform Size	Load Capacity
	mm	kg
2510.24.001	all	up to 3500

Drive-on ramps, smooth

Painted, colour black
For on-floor installed scales

Order Number	Platform Size	Ramp Size
	mm	mm
2505.05.001	1000 x 800	1000 x 800 x 80
2505.05.002	1250 x 1000	1000 x 1000 x 80
2505.05.003	1500 x 1250	1000 x 1250 x 80
2505.05.005	2000 x 1500	1000 x 1500 x 100

Drive-on ramps, smooth

Stainless steel 1.4301, drive-on ramps one or two sided
For on-floor installed scales

Order Number	Platform Size	Ramp Size
	mm	mm
2505.06.001	1000 x 800	1000 x 800 x 80
2505.06.002	1250 x 1000	1000 x 1000 x 80
2505.06.003	1500 x 1250	1000 x 1250 x 80
2505.06.005	2000 x 1500	1000 x 1500 x 100

Floor stand, painted or stainless steel

Order Number	Description	Dimensions
Floor stand, painted		mm
2504.10.001	For floor bolting, dimensions with floor platform 200 x 200mm	1150
2504.11.001	Bracket socket, setting without bolting	390 x 390
Order Number	Description	Dimensions
Floor stand, stainless steel		mm
2504.20.001	For floor bolting, dimensions with floor platform 200 x 200mm	1150
2504.21.001	Bracket socket, setting without bolting	390 x 390

Accessories for indicators 2790, 3020

Accessories for indicator 2790

Order Number	Description
2550.03.002	Data cable 2m, for PC/data processing

Accessories for standard terminal 3020

Order Number	Description
2563.21.002	2nd interface RS 232 assembled
2503.20.001	Wall-/Stand bracket stainless steel
2550.03.002	Data cable 2m, connection 3020-PC
2550.00.008	Data cable extension up to 10m
2550.03.007	Printing cable 2m, for printer 2795
2550.00.009	Printer cable extension up to 10m
2563.10.001	Ethernet WLAN-connection configured
2563.11.001	Ethernet connection configured
2563.12.001	Bluetooth™ adapter configured
2570.01.001	Power supply UK assembled
2570.01.002	Power supply US assembled
2570.01.003	Power supply CH assembled

Pictures

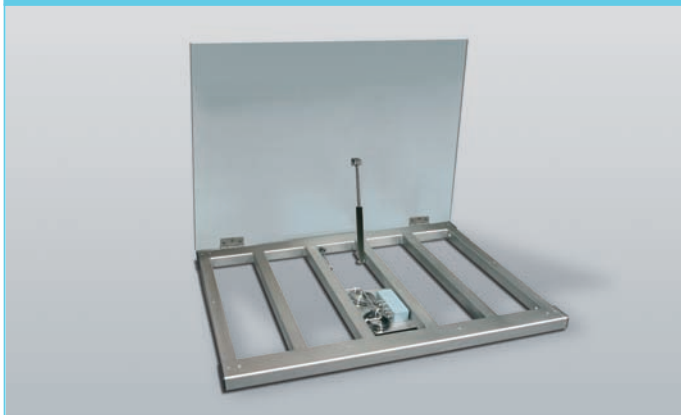

Stainless steel weighing platform hinged



Stainless steel weighing platform bolted



Steel weighing platform painted and bolted

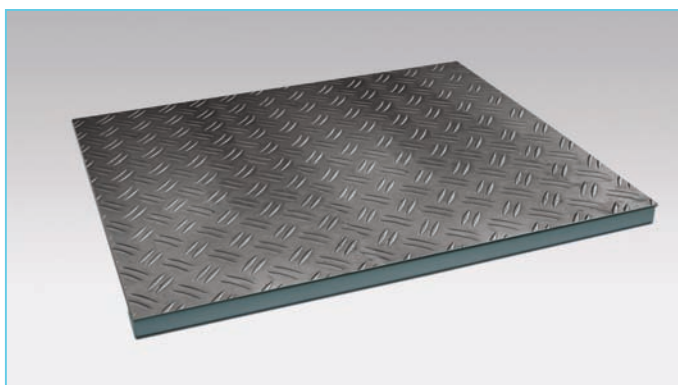

Stainless steel weighing platform, also available with anti-slip stainless steel structured platform

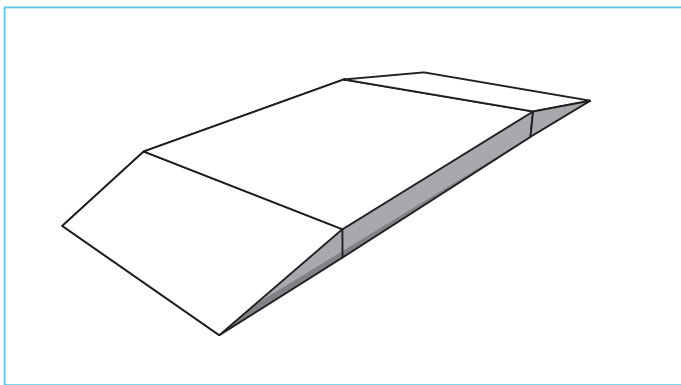

Version with drive-on ramps

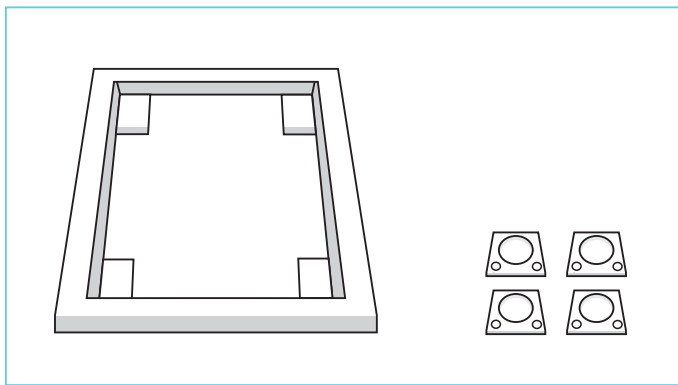

Installation frame to fix the scales set on-floor



Indicator 2790



Indicator 3020

FOR MEASURABLE SUCCESS

SOEHNLE
PROFESSIONAL

Your Soehnle Professional dealer:

www.soehnle-professional.com